

Product Data Sheet

iBar 800D

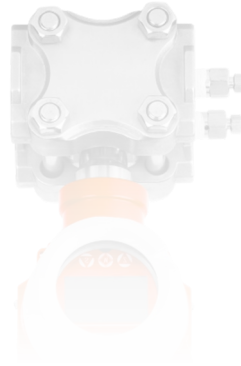
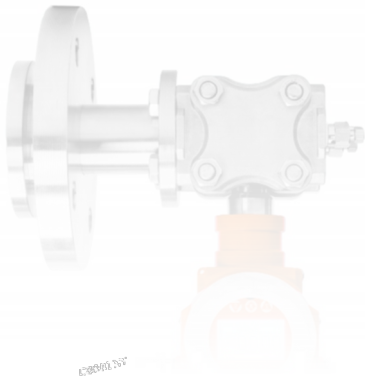

5 YEARS WARRANTY

HART
COMMUNICATION PROTOCOL



Differential Pressure Measurement 

Product introduction

The iBar 800D Series mono silicon pressure transmitter is high-performance with leading international technology. It has been meticulously designed using the world's most advanced mono-silicon pressure sensor and patent encapsulation technology.

The mono silicon pressure sensor is located on the top of the metal body and stays away from the medium interface to realize mechanical and thermal isolation. Glass sintering sensor wire realizes high strength electrical insulation of the metal base. All these original encapsulation technologies enable iBar 800D to cope with extreme chemical occasions easily and mechanical loads and own strong resistance to EMI, sufficient to respond to the most rigorous industrial environment applications.

Benefits

- ✓ Originally patented fully sealed, fully isolated mono silicon pressure sensor
- ✓ Double diaphragm overload protection structure can easily cope with high overload test.
- ✓ Multiple temperature and linearity compensation to improve accuracy.
- ✓ High strength metal electrical protection housing meets the most rigorous environmental application.
- ✓ Strong transient voltage resistance to protect terminal module.
- ✓ The three-button external menu function allows setup, calibration, and troubleshooting in the classified area.
- ✓ Backlit display for high visibility in dark environment
- ✓ High turn-down 100:1 without losing accuracy.

Applications

- ✓ Liquids, Gases, Vapours
- ✓ Aggressive Chemicals
- ✓ High temperature
- ✓ Density
- ✓ Tank Level
- ✓ DP across Filter
- ✓ DP flow

Technical Specifications

Measuring Range	200Pa...+10MPa (0.03psi...+1450psi)
Electrical Output	4...20mA (2-wire) 4...20mA+HART (2-wire) ModbusRTU/RS485
Process Temperature	Silicon oil filling: -40...+120°C, higher temperature available
Accuracy	±0.075% FS, optional ±0.05% FS (±0.2%, ±0.5% remote seal option)
Measuring Medium	Liquids, gases, steam
Stability	±0.2% URL/5 years
Power Supply	24VDC
Power Consumption	≤500mW@24VDC, 20.8mA
Ambient Temperature	-40...+85°C, integrated LCD display: -20...+70°C
Potection Class	IP 67
Process Connection	¼” NPTF, Various flange sizes for gauge pressure, tri-clamp
Diaphragm Material	SS316, Hastelloy C, Tantalum
Approvals	CE, CSA Class I, II, III Div 1 (pending)

Product Drawing & dimensions (mm)

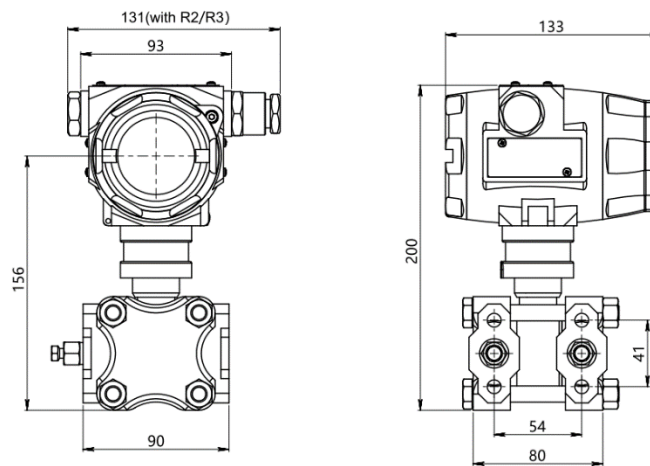

Current Instrumentation & Automatuon Inc.

11-680 Tradewind Dr., Hamilton, Canada L9G 4V5

E-mail: info@currentinstrument.ca

Phone: +1 905 802 9703

www.currentinstrument.ca